



CAR AND TRUCK TURNTABLES

---

HERCULES CARPARKING SYSTEMS





# a fast turnaround

---

Carparking can absorb enormous amounts of valuable space in a building, much of it just for turning space. Vehicle collisions are likely to happen when drivers manoeuvre in tight spaces, and the long-term cost of even minor collisions and repairs can be very high in both monetary and environmental terms.

Hercules Carparking Systems has a space-saving solution and can provide reliable access for vehicles in a tight space, avoiding the need for reversing and multiple-point turns.

A vehicle turntable is the ideal solution.



For the past fifteen years, Hercules Carparking Systems has been providing space-efficient vehicle storage for both residential and commercial applications. We design, import, install and service Dependent and Independent systems as well as Car Lifts and Turntables. Uniquely an Australian owned and based car parking company, we are fully committed to the Australian market.

Specialising in customised solutions for every conceivable parking requirement, using products sourced from around the world, our customers are not restricted to a 'one size fits all' approach.

Our management team of fully qualified engineers based here in Australia can attend meetings at your convenience and design a carparking solution to meet your unique requirements. Hercules understands the importance of professional project management on every job, no matter the size or scope. We have often been told we say 'Yes' more often than our opposition do, We focus on functionality, safety, reliability, efficient and sustainable technologies and cost-effectiveness.

Our management, engineers, designers, project managers and administrators are available 24/7 to liaise with you on your project. We are very proud of our knowledgeable, friendly and professional team of experts.

Be assured that Hercules is involved in every step of the process, from design to installation, to servicing and maintenance agreements.

# Why choose a Hercules Turntable?





# Made just for you

## SIZE

- Our domestic vehicle turntables range from 3 metres up to 9 metres in diameter. The most common size for residential use is the 4.5 metre diameter turntable with a 3 tonne capacity.
- So far the biggest turntable produced was a 25m diameter turntable rated to 45 tonnes!

## CAPACITY

- from 3 tonnes up to 100 tonnes, you tell us what your site requires.

## OPERATION

- Manual operation
- Remote Control operation

## TOP SURFACE

- Checker plate
- Aluminium
- Timber
- Tiled
- Concrete

Outdoor turn tables have the option to be galvanized.

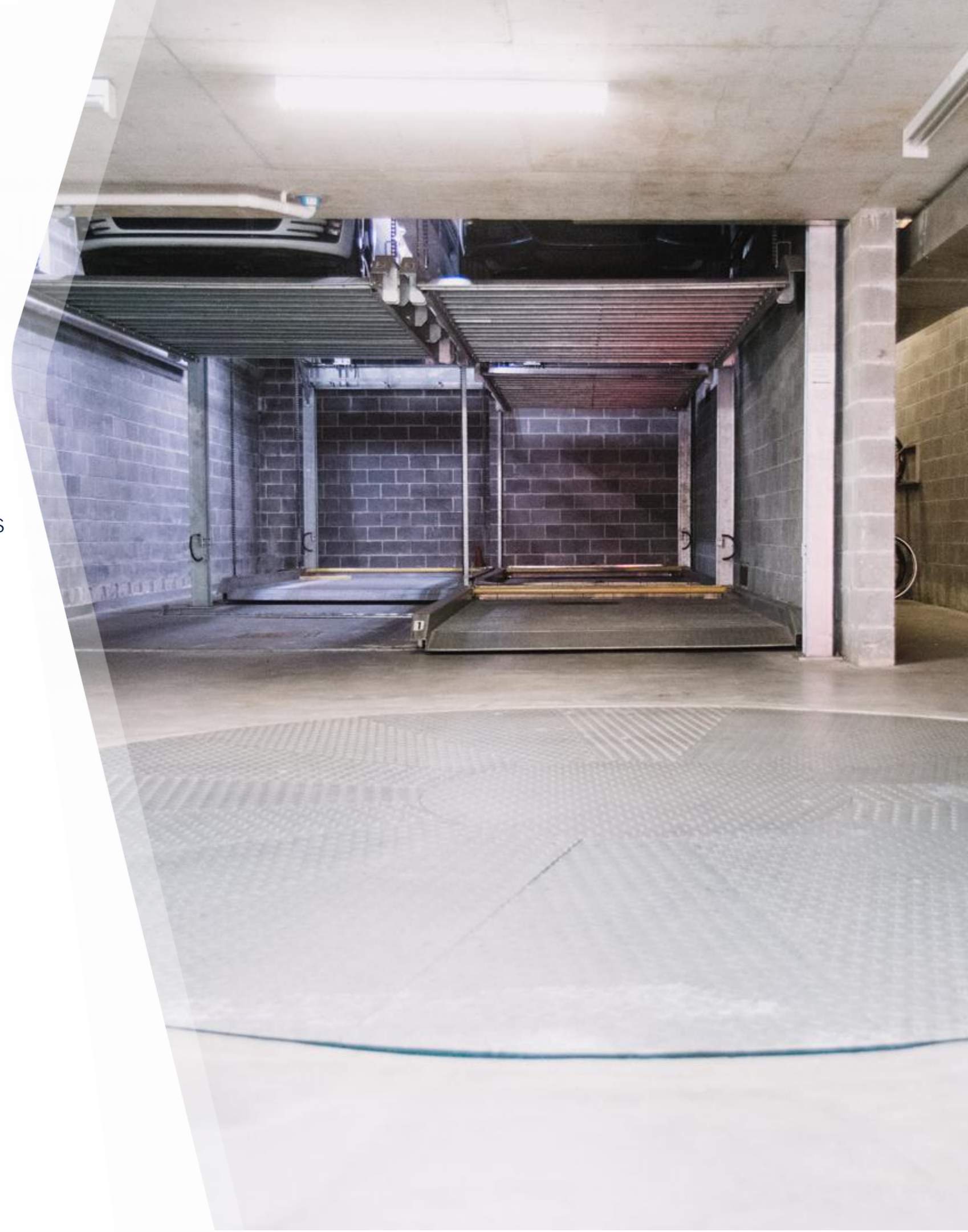



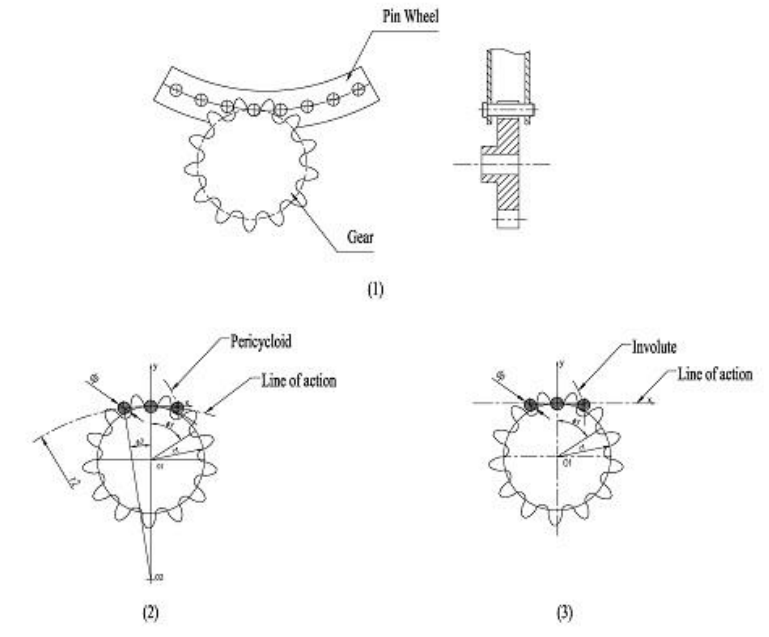
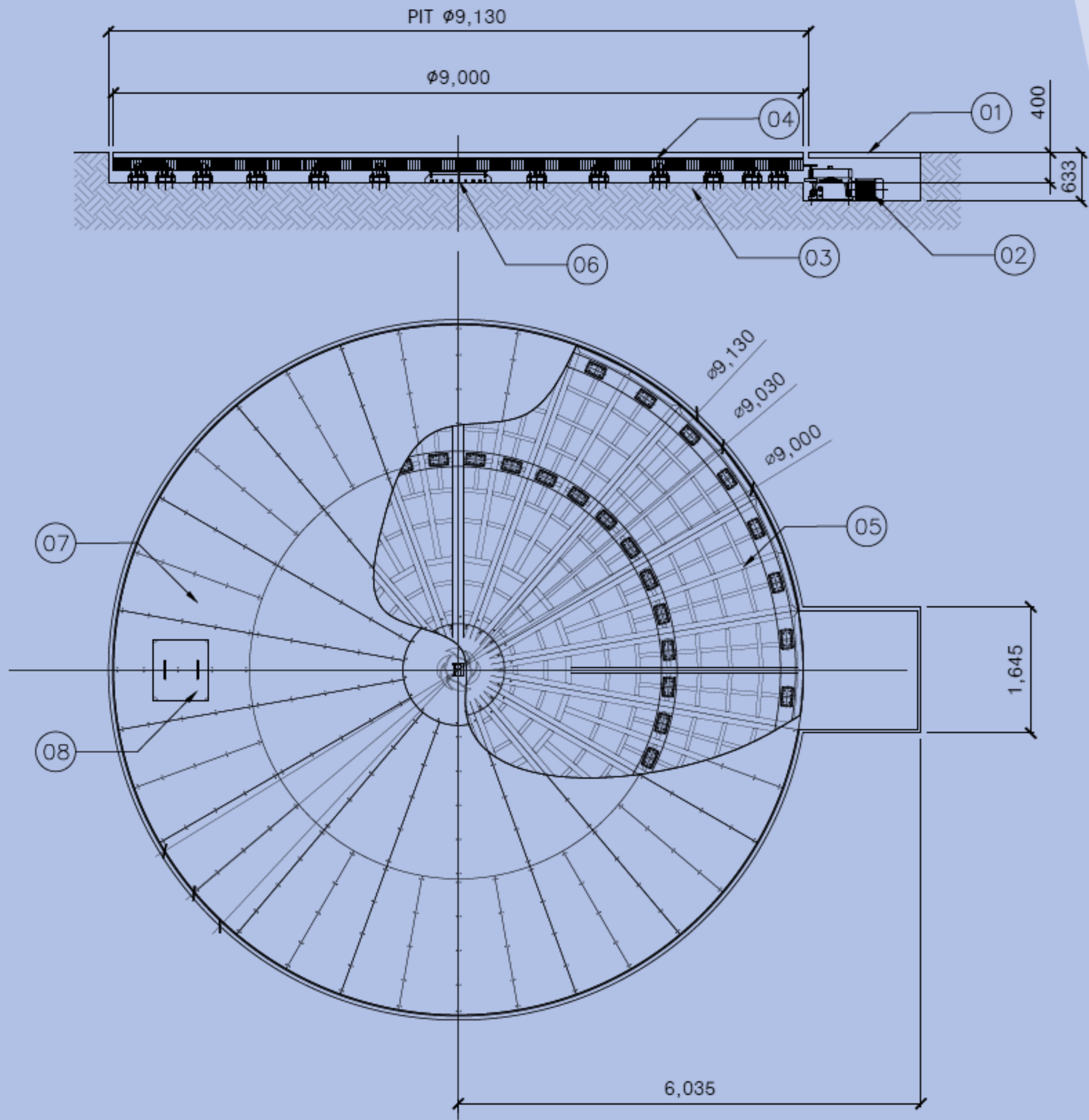

# Pin-Drive Technology

Unlike regular turntables which rely on a drive wheel pushing on an inner frame to rotate the table - the Hercules system uses a pin-drive which lasts many times longer.

The Pin Gear Drive Mechanism provides a smooth, reliable turntable operation with minimal wear and tear. It is also much quieter than the noisy friction drive option which requires considerably more maintenance than the Pin Drive option we provide.

## BENEFITS OF THE PIN-DRIVE

- Quiet operation
- No slipping
- Less wear on drive wheel
- Low maintenance



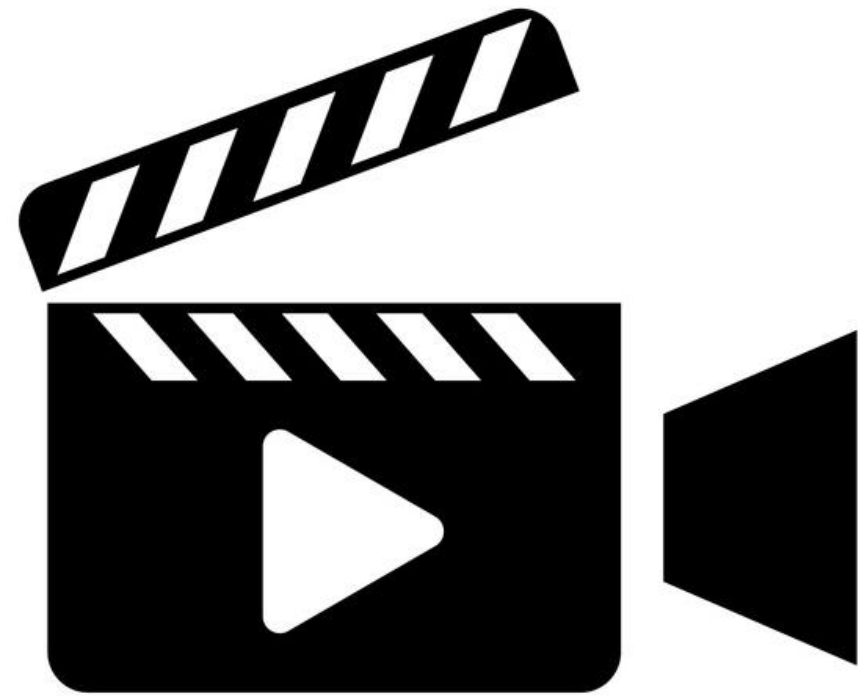

**VIDEO**

<https://www.youtube.com/watch?v=oQfD8E43EQ8&list=PLHmxcyVODZjdwsZB4G43r5CtKXGSiXpHE>

**HERCULES TURNTABLES**

The solution for turning your vehicle on the spot.

# Thank you.

Hercules Carparking Systems 2004  
ABN: 67 077 434 452  
Unit 1 / 87 Reserve Road  
ARTARMON NSW 2064

Hercules Carparking Systems (Melbourne)  
ABN: 72 622 520 281  
Unit 6 / 1 Bell Street  
PRESTON VIC 3072

Hercules Carparking Systems (Qld)  
ABN: 30 625 912 469  
Unit 1 / 87 Reserve Road  
ARTARMON NSW 2064

Hercules Carparking Systems (WA)  
ABN: 29 617 098 487  
41 Esplanade  
NEDLANDS WA 6009

